

C-BAND OPTICAL POWER BOOSTER

Description

This semiconductor optical amplifier is primarily intended for use as an optical power booster in high bit rate systems. Its high output saturation power level provides a compact and low cost alternative to competing approaches. The SOA booster amplifier package includes a thermistor and thermo-electric cooler in a 14-pin butterfly package with single mode fibre pigtails.

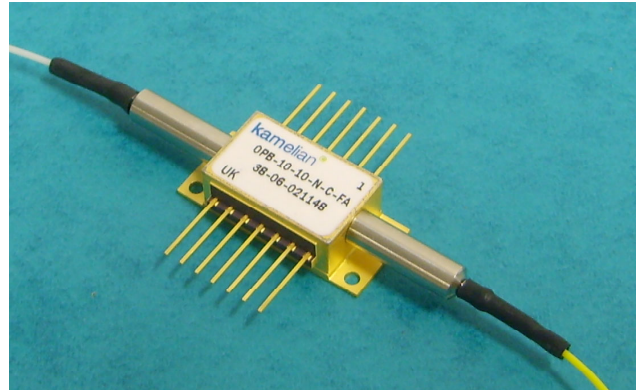

Applications

This product is appropriate for both metro and long haul applications. Two variants are available – low gain (min 10dB), and medium gain (min 15dB). The former is appropriate for use at a transmitter for moderate power laser and modulator tandems. The medium gain variant is intended for mid span applications such as OADM nodes, and low channel count line amps.

FEATURES

- 1550nm WINDOW
- HIGH OUPUT POWER
- LOW POLARISATION DEPENDENCE
- LOW NOISE FIGURE
- COMPACT PACKAGE
- MSA COMPLIANT

Specifications

(C Band 1529-1563 nm)

PARAMETER	MIN SPECIFICATION	TYPICAL SPECIFICATION	MAX SPECIFICATION
Fiber-to-fiber gain OPB-XX-10*	10dB		
Fiber-to-fiber gain OPB-XX-15*	15dB		
Noise figure (>5 dB gain)		6dB	7dB
Saturation output power OPB-10-YY	10dBm	11dBm	
Saturation output power OPB-12-YY	12dBm	13dBm	
Polarisation dependence		0.5dB	0.8dB
Gain ripple		0.3dB	0.5dB
Bias current		200mA	250mA
Operating temp	-5°C		70°C
TEC Drive Max		0.7A/1.5V	

Pin Allocation & Package Dimensions

PIN	DEFINITION	PIN	DEFINITION
1	TEC +	8	NC
2	THERMISTOR	9	NC
3	NC	10	SOA ANODE (+)
4	NC	11	SOA CATHODE (-)
5	THERMISTOR	12	NC
6	NC	13	CASE GND
7	NC	14	TEC -

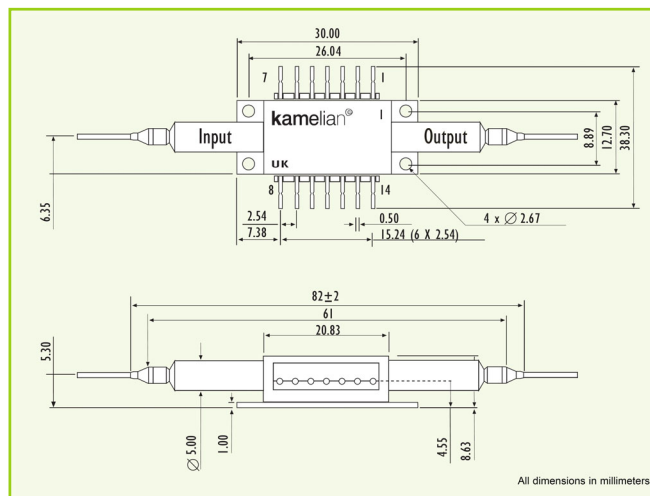

FIBER CONNECTOR	
CODE	CONNECTOR TYPE
FP	FC/PC
FA	FC/APC
FU	FC/UPC
LP	LC/PC
LA	LC/APC
LU	LC/UPC
SP	SC/PC
SA	SC/APC
SU	SC/UPC
ØØ	None

Ordering Information

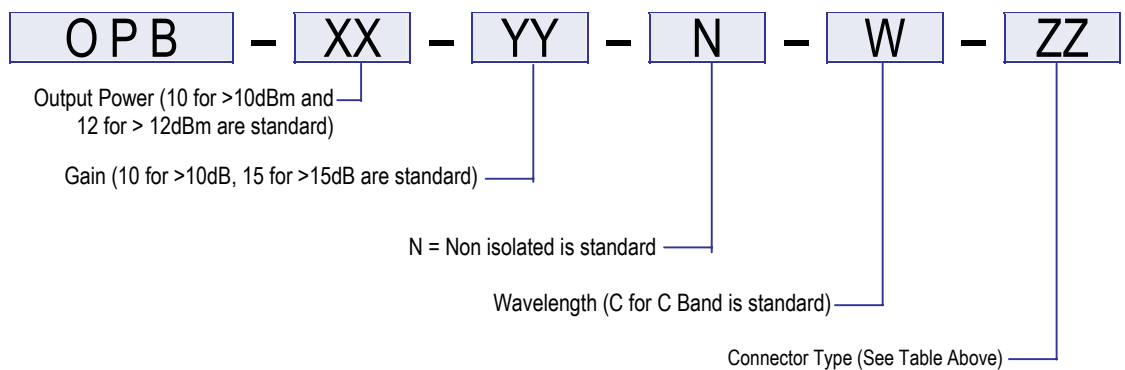

Amphotonix reserves the right to make changes in design, specifications and other information at any time, and without prior notice. The information contained within this Data Sheet is believed to be accurate. However, no responsibility is assumed for possible inaccuracy or omission. Any information contained herein shall legally bind Amphotonix only if it is specifically incorporated into the terms and conditions of a sales agreement.

AMPHOTONIX LIMITED